

DESIGN NOTES

New Voltage References Are Smaller and More Precise

Design Note 145

John Wright

Introduction

Two new series voltage references bridge the gap between small package size and high precision. Advances in design, process and packaging have made the introduction of these new voltage references possible. The low power LT[®]1460 is designed for minimum space and is available in all popular voltages, including 2.5V, 5V and 10V. By contrast, the LT1236 is designed for use in 12-bit and higher systems and combines 0.05% accuracy, low noise, low drift and the SO-8 package for difficult industrial temperature range applications.

Longer Battery Life with Precision

The LT1460 low power, series reference has a large advantage over older shunt-style references. Shunt references require a resistor from the power supply to operate. This resistor must be chosen to supply the maximum current that can ever be demanded by the circuit being regulated. When the circuit being controlled is not operating at this maximum current, the shunt reference must always sink this current, resulting in high dissipation and short battery life. Because the LT1460 does not require a current setting resistor, it can operate with any supply voltage from $V_{OUT} + 0.9V$ to 20V, while maintaining minimum dissipation and extending battery life. For example, if the 2.5V reference is not delivering load current, it dissipates only 500 μ W on a 5V supply, yet the same connection can deliver 20mA of load current on demand.

High output accuracy is achieved by the use of trimmed, precision thin-film resistors and curvature compensation is used to reduce drift. The LT1460 family is offered in MSOP, SO-8, PDIP and low cost TO-92 packages.

 LTC and LT are registered trademarks of Linear Technology Corporation.

The Small Fry

By themselves, surface mount packages are space efficient, but the use of a large output capacitor to stabilize the reference limits the benefits of the small package. The LT1460 is stable with capacitive loads or with no capacitor at all. This can be helpful when fast settling is a goal, because changes in the voltage across load capacitors must recover before the reference's output value is accurate.

The MSOP LT1460 uses so little PC board space that there is a temptation to use the device as a local regulator. This is exactly what the LT1460 was designed to do: deliver substantial load current while maintaining reference-like features. At $I_{OUT} = 20mA$, typical load regulation is 70ppm/mA, yet the LT1460 can withstand a short to ground without being destroyed. Additionally, if the power supplies are reversed, the reverse battery protection keeps the reference from conducting current and being damaged.

Table 1. Key Specifications of the LT1460-2.5 Voltage Reference (SO-8 Package)

PARAMETER	CONDITIONS	MAX VALUE
Output Voltage Tolerance LT1460A LT1460B		0.075% 0.10%
Temperature Coefficient LT1460A LT1460B	$0^{\circ}C \leq T_A \leq 70^{\circ}C$	10ppm/ $^{\circ}C$ 20ppm/ $^{\circ}C$
Line Regulation	5V to 20V	25ppm/V
Load Regulation Sourcing	$0mA \leq I_{OUT} \leq 20mA$	100ppm/mA
Dropout Voltage	$I_{OUT} = 0mA$, $0^{\circ}C \leq T_A \leq 70^{\circ}C$	0.9V
Supply Current	$I_{OUT} = 0mA$	130 μ A
Reverse Leakage	$I_{OUT} = 0mA$, $V_{IN} = -20V$	10 μ A

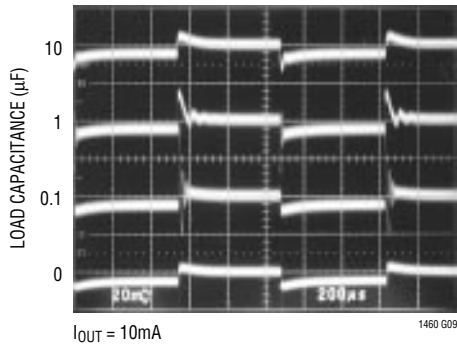

Figure 1. Transient Response

Higher Performance, Industrial Temperature Range and Surface Mount

The LT1236 is a precision reference that combines ultralow drift and noise with excellent long term stability and high output accuracy. To address small package requirements, the new reference is available in the SO-8 package and guarantees critical reference parameters from -40°C to 85°C . The LT1236 output will both source and sink 10mA, is almost totally immune to input voltage variations and is stable with any load capacitor. Two output voltages are available: 5V and 10V. The 10V version can be used as a shunt regulator (2-terminal Zener) with the same precision characteristics as the 3-terminal connection. Special

care has been taken to minimize thermal regulation effects and temperature-induced hysteresis. The LT1236 is also available in an N8 package.

The LT1236 combines superior accuracy and temperature coefficient specifications without the use of high power, on-chip heaters. The LT1236 references are based on a buried Zener diode structure that eliminates noise and stability problems that plague surface-breakdown devices.

Table 2. Key Specifications of the LT1236-10 Voltage Reference (SO-8 Package)

PARAMETER	CONDITIONS	MAX VALUE
Output Voltage Tolerance		
LT1236A		0.05%
LT1236B		0.10%
LT1236C		0.10%
Temperature Coefficient	$-40^{\circ}\text{C} \leq T_A \leq 85^{\circ}\text{C}$	
LT1236A		5ppm/ $^{\circ}\text{C}$
LT1236B		10ppm/ $^{\circ}\text{C}$
LT1236C		15ppm/ $^{\circ}\text{C}$
Line Regulation	$11.5\text{V} \leq V_{\text{IN}} \leq 14.5\text{V}$	4ppm/V
Load Regulation Sourcing	$0\text{mA} \leq I_{\text{OUT}} \leq 10\text{mA}$	25ppm/mA
Output Noise Voltage	$10\text{Hz} \leq f \leq 1\text{kHz}$	$6\mu\text{V}_{\text{RMS}}$
Supply Current	$I_{\text{OUT}} = 0\text{mA}$	1.7mA

CMOS DAC with Low Drift Full-Scale Trimming**

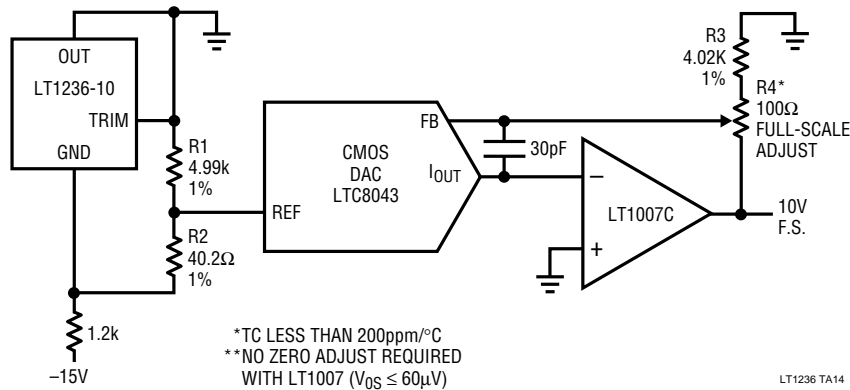

For literature on our Voltage References, call **1-800-4-LINEAR**. For applications help, call (408) 432-1900, Ext. 2456